

UNIT -6

1. Draw the Maxwell's Bridge Circuit and derives the expression for the unknown element at balance?

Ans:

Maxwell's bridge, shown in Fig. 1.1, measures an unknown inductance in of standard arm offers the advantage of compactness and easy shielding. The capacitor is almost a loss-less component. One arm has a resistance R_x in parallel with C_u and hence it is easier to write the balance equation using the admittance of arm 1 instead of the impedance.

The general equation for bridge balance is

$$Z_x = \frac{Z_2 Z_3}{Z_1} = Z_2 Z_3 Y_1$$

$$Z_1 = R_1 \text{ in parallel with } C_1 \text{ i.e. } Y_1 = \frac{1}{Z}$$

$$Y_1 = \frac{1}{R_1} + j\omega C_1$$

$$Z_2 = R_2$$

$$Z_3 = R_3$$

$$Z_x = R_x \text{ in series with } L_x = R_x + j\omega L_x$$

From equation of Z_x we get

$$R_x + j\omega L_x = R_2 R_3 \left(\frac{1}{R_1} + j\omega C_1 \right)$$

$$R_x + j\omega L_x = \frac{R_2 R_3}{R_1} + j\omega C_1 R_2 R_3$$

Equating real terms and imaginary terms we have

$$R_x = \frac{R_2 R_3}{R_1} \text{ and } L_x = C_1 R_2 R_3$$

Also

$$Q = \frac{\omega L_x}{R_x} = \frac{\omega C_1 R_2 R_3 \times R_1}{R_2 R_3} = \omega C_1 R_1$$

Maxwell's bridge is limited to the measurement of low Q values (1 -10).The measurement is independent of the excitation frequency. The scale of the resistance can be calibrated to read inductance directly.

The Maxwell bridge using a fixed capacitor has the disadvantage that there an interaction between the resistance and reactance balances. This can be avoids: by varying the capacitances, instead of R_2 and ft, to obtain a reactance balance. However, the bridge can be made to read directly in Q .

The bridge is particularly suited for inductances measurements, since comparison on with a capacitor is more ideal than with another inductance. Commercial bridges measure from 1 – 1000H. With $\pm 2\%$ error. (If the Q is very becomes excessively large and it is impractical to obtain a satisfactory variable standard resistance in the range of values required).

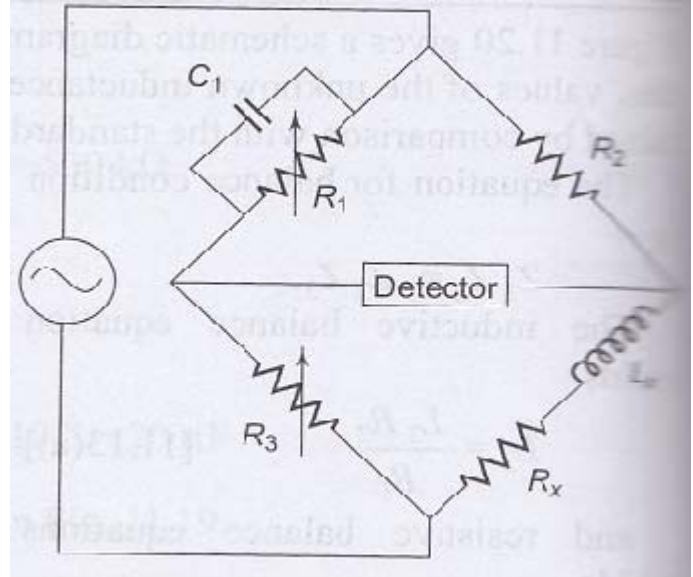

fig 1.1. Maxwell's Bridge

2. Draw the Wien's Bridge Circuit and derives the expression for the unknown element at balance?

Ans: Wien Bridge shown in Fig. 2.1 has a series RC combination in one and a parallel combination in the adjoining arm. Wien's bridge in its basic form is designed to measure frequency. It can also be used for the instrument of an unknown capacitor with great accuracy,

The impedance of one arm is

$$Z_1 = R_1 - j/\omega C_1$$

The admittance of the parallel arm is

$$Y_3 = 1/R_3 + j \omega C_3$$

Using the bridge balance equation, we have

We have

$$Z_1 Z_4 = Z_2 Z_3$$

Therefore

$$Z_1 Z_4 = Z_2/Y_3, \text{ i.e. } Z_2 = Z_1 Z_4 Y_3$$

$$R_2 = R_4 \left(R_1 - \frac{j}{\omega C_1} \right) \left(\frac{1}{R_3} + j \omega C_3 \right)$$

$$R_2 = \frac{R_1 R_4}{R_3} - \frac{j R_4}{\omega C_1 R_3} + j \omega C_3 R_1 R_4 + \frac{C_3 R_4}{C_1}$$

$$R_2 = \left(\frac{R_1 R_4}{R_3} + \frac{C_3 R_4}{C_1} \right) - j \left(\frac{R_4}{\omega C_1 R_3} - \omega C_3 R_1 R_4 \right)$$

Equating the real and imaginary terms we have

$$R_2 = \frac{R_1 R_4}{R_3} + \frac{C_3 R_4}{C_1} \quad \text{and} \quad \frac{R_4}{\omega C_1 R_3} - \omega C_3 R_1 R_4 = 0$$

Therefore

$$\frac{R_2}{R_4} = \frac{R_1}{R_3} + \frac{C_3}{C_1} \quad \dots\dots\dots (1.1)$$

And

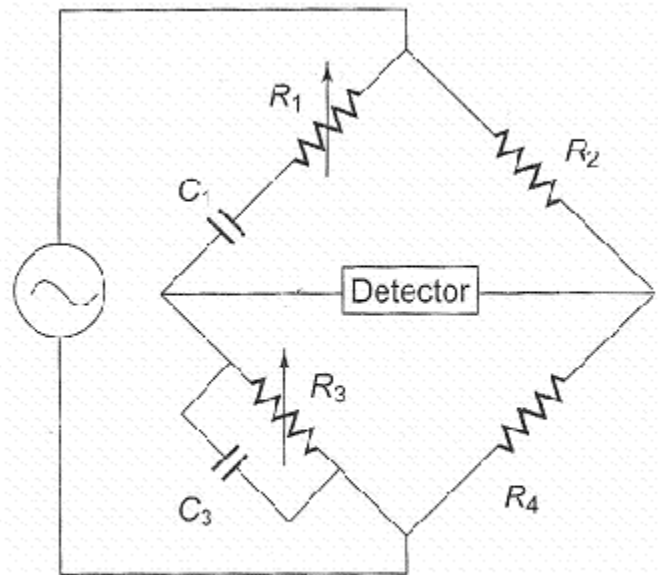

fig 2.1 Wein's Bridge

$$\frac{1}{\omega C_1 R_3} = \omega C_3 R_1 \quad \dots\dots\dots(1.2)$$

$$\omega^2 = \frac{1}{C_1 R_1 R_3 C_3}$$

$$\omega = \frac{1}{\sqrt{C_1 R_1 C_3 R_3}}$$

$$\omega = 2 \pi f$$

$$f = \frac{1}{2 \pi \sqrt{C_1 R_1 C_3 R_3}} \quad \dots\dots\dots(1.3)$$

The two conditions for bridge balance, (1.1) and (1.3), result in an expression determining the required resistance ratio R_2/R_4 and another express determining the frequency of the applied voltage. If we satisfy Eq. (1.1) an also excite the bridge with the frequency of Eq. (1.3), the bridge will be balanced.

In most Wien bridge circuits, the components are chosen such that $R_1 = R_3 = R$ and $C_1 = C_3 = C$. Equation (1.1) therefore reduces to $R_2/R_4 = 2$ at Eq. (1.3) to $f = \frac{1}{2\pi RC}$, which is the general equation for the frequency of fl bridge circuit.

The bridge is used for measuring frequency in the audio range. Resistances R_1 and R_3 can be ganged together to have identical values. Capacitors C_1 and C_3 are normally of fixed values

The audio range is normally divided into 20 - 200 - 2 k - 20 kHz range In this case, the resistances can be used for range changing and capacitors, and C_3 for fine frequency control within the range. The bridge can also be use for measuring capacitances. In that case, the frequency of operation must be known.

The bridge is also used in a harmonic distortion analyzer, as a Notch filter, an in audio frequency and radio frequency oscillators as a frequency determine element.

An accuracy of 0.5% - 1% can be readily obtained using this bridge. Because it is frequency sensitive, it is difficult to balance unless the waveform of the applied voltage is purely sinusoidal.

3. Draw the Hay's Bridge Circuit and derives the expression for the unknown element at balance?

Ans:

The Hay Bridge, shown in Fig. 3.1 differs from Maxwell's bridge by having a resistance R_1 in series with a standard capacitor C_1 instead of a parallel. For large phase angles, R_1 needs to be low; therefore, this bridge is more convenient for measuring high Q coils. For $Q=10$, the error is $\pm 1\%$, and for $Q = 30$, the is $\pm 0.1\%$. Hence Hay's bridge is preferred for coils with a high Q, and Ma bridge for coils with a low Q.

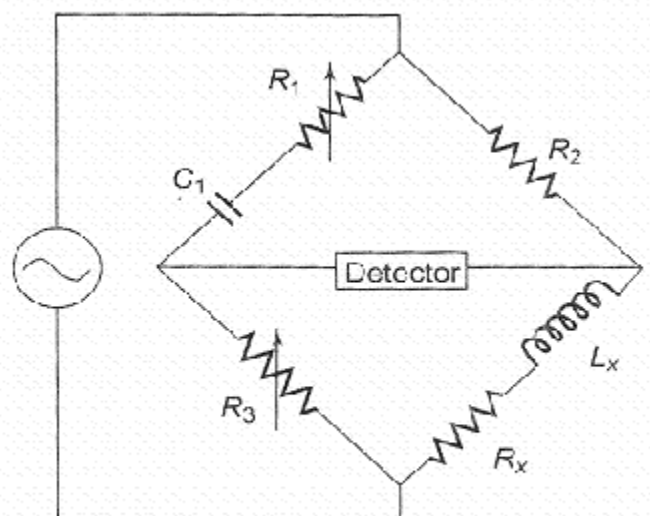

fig 3.1 Hay's Bridge

$$\text{At balance} \quad Z_1 Z_x = Z_2 Z_3$$

$$Z_1 = R_1 - j/\omega C_1$$

$$Z_2 = R_2$$

$$Z_3 = R_3$$

$$Z_x = R_x + j\omega L_x$$

Substituting these values in the balance equation we get

$$\left(R_1 - \frac{j}{\omega C_1} \right) (R_x + j\omega L_x) = R_2 R_3$$

$$R_1 R_x + \frac{L_x}{C_1} - \frac{j R_x}{\omega C_1} + j\omega L_x R_1 = R_2 R_3$$

Equating the real and imaginary terms we have

$$R_1 R_x + \frac{L_x}{C_1} = R_2 R_3 \quad \dots\dots\dots(1.1)$$

$$\frac{R_x}{\omega C_1} = \omega L_x R_1 \quad \dots\dots(1.2)$$

in and

Solving for L_x and R_x we have, $R_x = \omega^2 L_x C_1 R_1$

Substituting for R_x in equation 1.1

$$R_1 (\omega^2 R_1 C_1 L_x) + \frac{L_x}{C_1} = R_2 R_3$$

$$\omega^2 R_1^2 C_1 L_x + \frac{L_x}{C_1} = R_2 R_3$$

Multiply both sides by C_1 we get

$$\omega^2 R_1^2 C_1^2 L_x + L_x = R_2 R_3 C_1$$

Therefore,

$$L_x = \frac{R_2 R_3 C_1}{1 + \omega^2 R_1^2 C_1^2}$$

Substituting for L_x in eq 1.2 we get

$$R_x = \frac{\omega^2 C_1^2 R_1 R_2 R_3}{1 + \omega^2 R_1^2 C_1^2}$$

The term ω appears in the expression for both L_x and R_x . This indicates that the bridge is frequency sensitive.

Hay Bridge is also used in the measurement of incremental inductance. The inductance balance equation depends on the losses of the inductor (or Q) and also on the operating frequency.

AN inconvenient feature of this bridge is that the equation giving the balance condition for inductance, contains the multiplier $1/(1 + 1/Q^2)$. The inductance balance thus depends on its Q and frequency.

$$I_1 = I_3 = \frac{E}{R_1 + R_3} \dots\dots\dots(1.2)$$

Therefore

$$I_2 = I_4 = \frac{E}{R_2 + R_4} \dots\dots\dots(1.3)$$

$$L_x = \frac{R_2 R_3 C_1}{1 + (1/Q)^2}$$

For a value of Q greater than 10, the term $1/Q^2$ will be smaller than $1/100$ and can be therefore neglected. Therefore $L_x = R_2 R_3 C_1$ which is the same as Maxwell's equation. But for inductors with a Q less than 10, the $1/Q^2$ term cannot be neglected. Hence this bridge is not suited for measurements of coils having Q less than 10. A commercial bridge measure from $1\mu\text{H} - 100 \text{ H}$ with $\pm 2\%$ error.

4. Draw the Wheat stone's Bridge Circuit and derives the expression for the unknown element at balance?

Ans:

WHEATSTONE'S BRIDGE (MEASUREMENT OF RESISTANCE)

Whetstone's bridge is the most accurate method available for measuring resistances and is popular for laboratory use. The circuit diagram of a Wheatstone bridge is given in Fig. 11.1. The source of emf and switch is connected to points A and S, while a sensitive current indicating meter, the galvanometer, is connected to points C and D. The galvanometer is a sensitive micro ammeter a zero center scale. When there is no current through the meter, the galvanometer pointer rests at 0, i.e. mid scale. Current in one direction causes the points deflect on one side and current in the opposite direction to the other side.

When SW_1 is closed, current flows and divides into the two arms at point A i.e. I_1 and I_2 . The bridge is balanced when there is no current through the galvanometer, or when the potential difference at points C and D is equal, i.e. the potential across the galvanometer is zero.

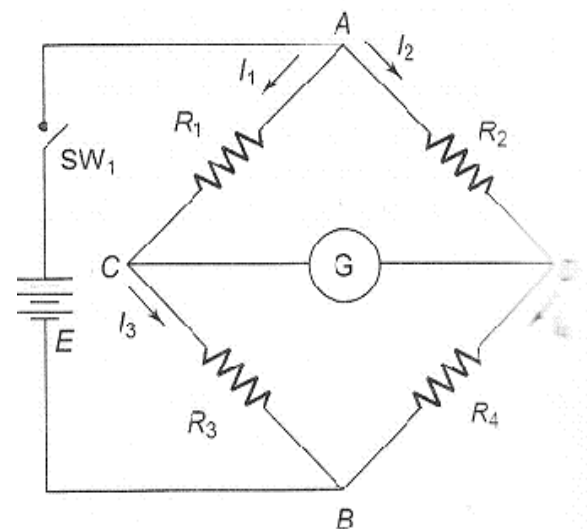

fig 4.1 Wheatstone's Bridge

To obtain the bridge balance equation, we have from the fig 4.1

For the galvanometer current to be zero, the following conditions should be satisfied

$$\frac{E \times R_1}{R_1 + R_3} = \frac{E \times R_2}{R_2 + R_4}$$

$$R_1 \times (R_2 + R_4) = (R_1 + R_3) \times R_2$$

$$R_1 R_2 + R_1 R_4 = R_1 R_2 + R_3 R_2$$

$$R_4 = \frac{R_2 R_3}{R_1}$$

This is the equation for the bridge to be balanced.

In a practical Whetstone's bridge, at least one of the resistance is made adjustable, to permit balancing. When the bridge is balanced, the unknown resistance (normally connected at R_x) may be determined from the setting of the adjustable resistor, which is called a standard resistor because it is a precision device having very small tolerance.

$$R_x = \frac{R_2 R_3}{R_1} \dots\dots\dots(1.4)$$

Hence

5. Explain about Ac bridges and also the precautions to be taken while using a Bridge?

Ans:

Impedances at AF or RF are commonly determined by means of an ac Wheatstone bridge. The diagram of an ac bridge is given in Fig. 11.17. This bridge is similar to a dc bridge, except that the bridge arms are impedances. The bridge is excited by an ac source rather than dc and the galvanometer is replaced by a detector, such as a pair of headphones, for detecting ac. When the bridge is

balanced,

$$\frac{Z_1}{Z_3} = \frac{Z_2}{Z_4}$$

Where Z_1 , Z_2 , Z_3 and Z_4 are the impedances of the arms, and are vector complex quantities that possess phase angles. It is thus necessary to adjust both the magnitude and phase angles of the impedance arms to achieve balance, i.e. the bridge must be balanced for both the reactance and the resistive component.

PRECAUTIONS TO BETAKEN WHEN USING A BRIDGE

Assuming that a suitable method of measurement has been selected and that i.e. source and detector are given, there are some precautions which must be observed to obtain accurate readings.

The leads should be carefully laid out in such a way that no loops or long lengths enclosing magnetic flux are produced, with consequent stray inductance errors. With a large L, the self-capacitance of the leads is more important than there inductance, so they should be spaced relatively far apart.

In measuring a capacitor, it is important to keep the lead capacitance as low as possible. For this reason the leads should not be too close together and should be made of fine wire.

In very precise inductive and capacitances measurements, leads are encased in metal tubes to shield them from mutual electromagnetic action, and are used or designed to completely shield the bridge

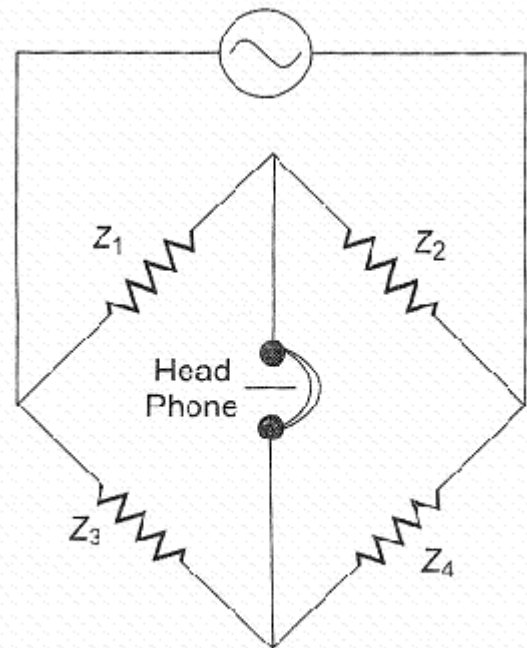

fig 5.1 ac wheatstone bridge

6. Draw the Andersons Bridge Circuit and derives the expression for the unknown element at balance?

Ans :

The Anderson Bridge is a very important and useful modification of the Maxwell-Wein bridge as shown in the fig 6.1 (a)

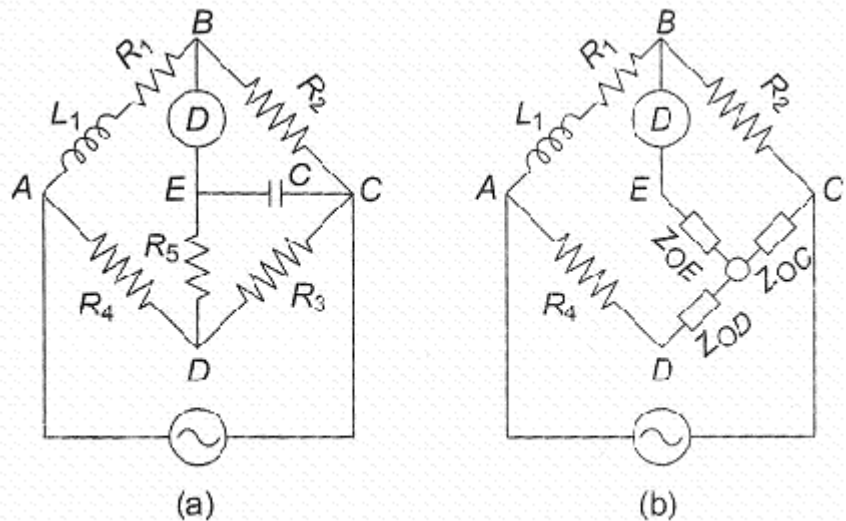

fig 6.1 Anderson's Bridge

The balance condition for this bridge can be easily obtained by converting the mesh impedance C, R_3, R_5 to a equivalent star with the star point 0 as shown in fig 6.1 (b) by using star/delta transformation

As per delta to star transformation

$$Z_{OD} = \frac{R_3 R_5}{(R_3 + R_5 + 1/j\omega C)} \quad Z_{OC} = \frac{R_3 / j\omega C}{(R_3 + R_5 + 1/j\omega C)} = Z_3$$

Hence with reference to fig 6.1(b) it can be seen that

$$Z_1 = (R_1 + j\omega L_1), Z_2 = R_2, Z_3 = Z_{OC} = \frac{R_3 / j\omega C}{(R_3 + R_5 + 1/j\omega C)} \text{ and } Z_4 = R_4 + Z_{OD}$$

For balance bridge condition,

$$Z_1 Z_3 = Z_2 Z_4$$

Therefore,
$$(R_1 + j\omega L_1) \times Z_{OC} = Z_2 \times (Z_4 + Z_{OD})$$

$$(R_1 + j\omega L_1) \times \left(\frac{R_3 / j\omega C}{(R_3 + R_5 + 1/j\omega C)} \right) = R_2 \left(R_4 + \frac{R_3 R_5}{(R_3 + R_5 + 1/j\omega C)} \right)$$

Simplifying,

$$(R_1 + j\omega L_1) \times \frac{R_3/j\omega C}{(R_3 + R_5 + 1/j\omega C)} = R_2 \left(R_4 (R_3 + R_5 + 1/j\omega C) + \frac{R_3 R_5}{(R_3 + R_5 + 1/j\omega C)} \right)$$

$$(R_1 + j\omega L_1) \times \frac{R_3}{j\omega C} = R_2 R_4 (R_3 + R_5 + 1/j\omega C) + R_2 R_3 R_5$$

$$\frac{R_1 R_3}{j\omega C} + \frac{j\omega L_1 R_3}{j\omega C} = R_2 R_3 R_4 + R_2 R_4 R_5 + \frac{R_2 R_4}{j\omega C} + R_2 R_3 R_5$$

$$\frac{-j R_1 R_3}{\omega C} + \frac{L_1 R_3}{C} = R_2 R_3 R_4 + R_2 R_4 R_5 - \frac{j R_2 R_4}{\omega C} + R_2 R_3 R_5$$

Equating the real terms and imaginary terms

$$\frac{L_1 R_3}{C} = R_2 R_3 R_4 + R_2 R_4 R_5 + R_2 R_3 R_5$$

$$L_1 = \frac{C}{R_3} (R_2 R_3 R_4 + R_2 R_4 R_5 + R_2 R_3 R_5)$$

$$L_1 = CR_2 \left[R_4 + \frac{R_4 R_5}{R_3} + R_5 \right]; \quad L_1 = CR_2 \left[R_4 + R_5 + \frac{R_4 R_5}{R_3} \right]$$

$$\frac{-j R_1 R_3}{\omega C} = \frac{-j R_2 R_4}{\omega C};$$

$$R_1 R_3 = R_2 R_4,$$

And therefore

$$R_1 = \frac{R_2 R_4}{R_3}$$

This method is capable of precise measurement of inductance and a wide range of values from a few μH to several Henry.

7. Compare the measuring accuracy of a Wheat stone bridge with the accuracy of an ordinary meter?

Ans:

Errors in PMMC Ammeters

The accuracy in a moving coil instruments example, an ammeter is dictated by the following sources of errors.

- (i) Weakening of permanent magnets due to ageing and temperature effects.
- (ii) The weakening of springs due to regular usage and temperature effects.

- (iii) Variation in Resistance of moving coil with temperature. The copper wire wound has a temperature coefficient of about $0.004/^{\circ}\text{C}$. When this instrument used for measurement of very small currents in the milli-amp or micro-amp range, the moving coil is directly connected to the output terminals of the instrument. The indication would then decrease by 0.04% per $^{\circ}\text{C}$ rise in temperature for a constant current.

Errors in Wheatstone bridge Measurements

The accuracy of measurement of resistance in a Wheatstone bridge is affected by the following sources.

- (i) Resistance of connecting leads and contact resistance.
- (ii) Thermo electric effects. The galvanometer deflection is affected by thermo electric emfs which are often present in the measuring circuit.
- (iii) Temperature effects: The change in resistance due to variation of temperature causes serious errors in measurement. The error are more predominant in the case of resistors are made up of materials having high temperature coefficients. In the case of copper having a temperature coefficient of $0.004/^{\circ}\text{C}$, a change in temperature of $\pm 1^{\circ}\text{C}$ causes an error of about $\pm 0.4\%$.

8. Draw the circuit of a basic Q-meter diagram and explain its principal of operation using a vector diagram?

Ans: The instrument which measures some of the electrical properties of coils and capacitors is referred as Q-meter. The working principle of a Q-meter depends on the characteristics of a series resonance circuits, i.e., the voltage drop across the coil or capacitors is equal to the applied voltage times the Q factor of the circuit. Thus if the circuit subjected to a fixed voltage, the voltmeter connected across the capacitor is calibrated to indicate the Q value directly. A series resonance circuit and its voltage and current relationship at resonance conditions are illustrated in figure 8.1 (i) and fig 8.1 (ii) respectively.

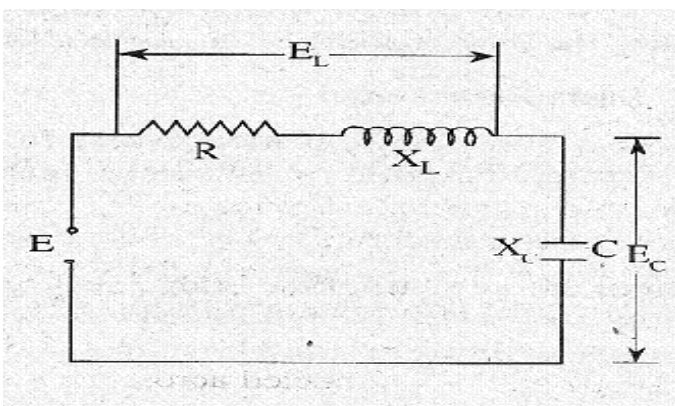

fig 8.1 (a) series resonate circuit

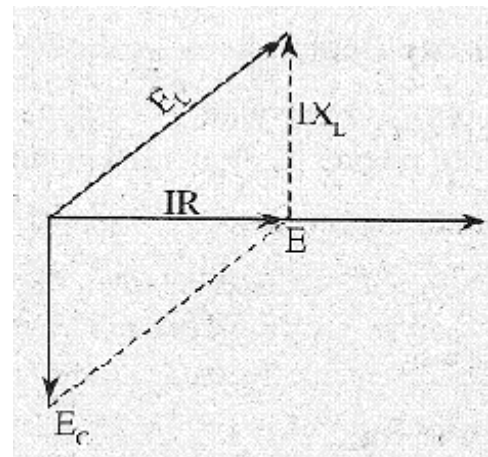

fig 8.1 (b) phasor diagram

At resonance condition,

$$X_L = X_C$$

$$E_C = IX_L = IX_C$$

$$E = IR$$

Where,

X_C = Capacitive reactance

X_L = Inductive reactance

I = Current flowing through the circuit

E = Applied voltage

R = Resistance of the coil

The Q factor or the magnification of the circuit is defined as,

$$Q = \frac{X_L}{R} = \frac{X_C}{R} = \frac{E_C}{E}$$

From the above equation it is clear that if the voltage E is maintained at a fixed level, the voltmeter across the capacitor can be calibrated in terms of Q directly. The circuit arrangement of basic and practical Q-meter is shown below.

The oscillator is a wide range RF oscillator that supplies the oscillations whose frequency lies between 50 kHz to 50 MHz and delivers current to R_{sh} which is a shunt resistance of low value, and is typically around $0.02Q$. Therefore the R_{sh} introduces very negligible (almost no resistance) resistance into the oscillator circuit. Thus it represents a voltage source of magnitude E with a very low internal resistance. The voltage across R_{sh} is measured using a thermocouple meter that is marked as 'multiply Q by meter'. The voltage drop across the tuning capacitor or resonating capacitor E_C is measured by means of an

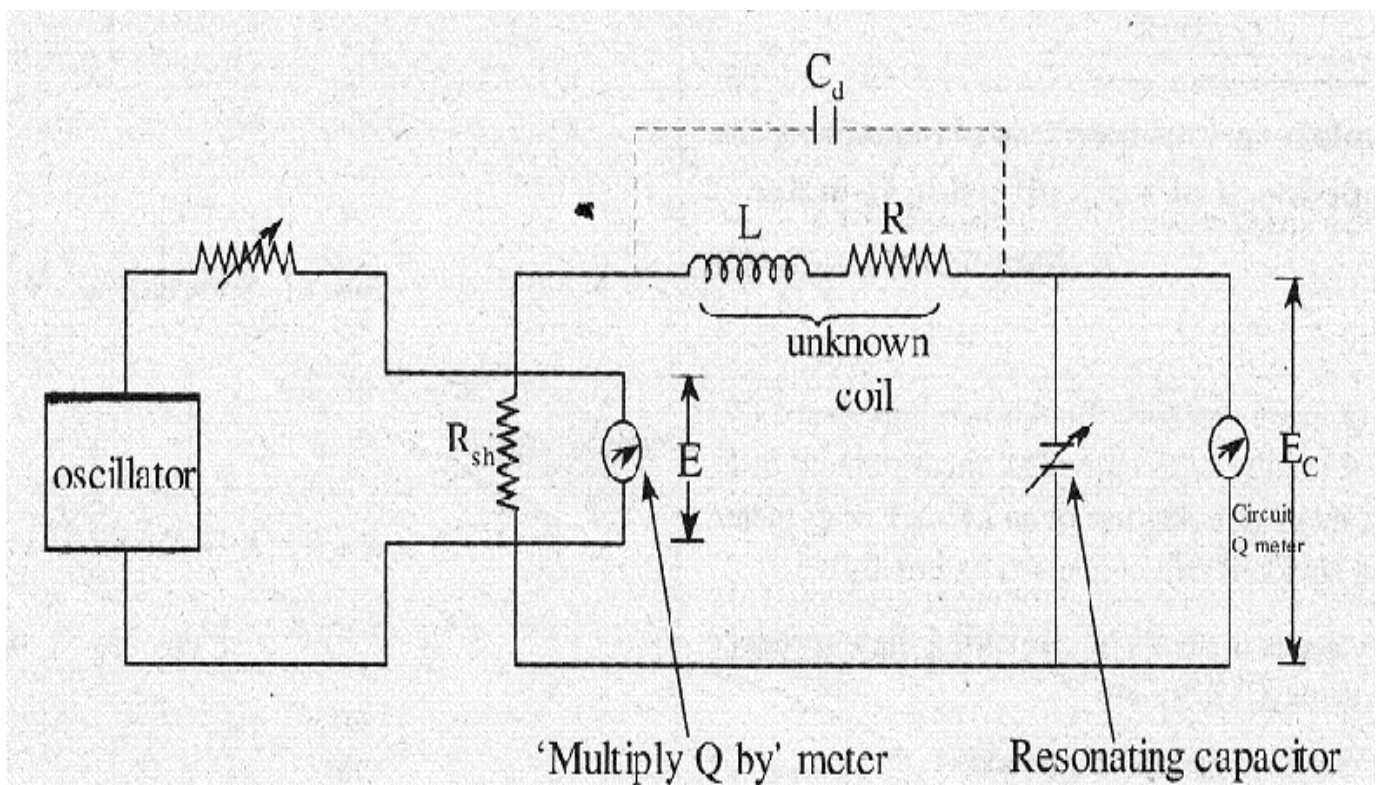

fig 8.2 Basic Q meter

electronic voltmeter. The scale of this electronic voltmeter is calibrated in terms of Q values directly.

To carry out the measurement the unknown components is connected across the test terminals and the circuit is adjusted to resonance using any one of the two methods given below.

By setting the frequency of the oscillator to a certain given value and adjusting the tuning capacitor.

By presetting the capacitor to a required value and varying the frequency of oscillator.

The Q value indicate on the output meter should be multiplied by the index setting of the 'multiply Q by' meter to get actual, or accurate Q value.

The indicated value of Q on the output meter is known as 'circuit Q' since it includes the losses of volt-meter tuning capacitor and insertion resistor. The effective Q value of the measured coil will be higher than indicated Q or circuit Q. This difference is small therefore it can be neglected. However this difference is large if the resistance of the coil is small compared to the insertion resistor value.

The inductance of the coil can be found from the known values of c (resonating capacitance) and / (frequency). Since $X_C = X_L$

$$2\pi fL = 1/2\pi fC$$

Therefore $L = 1 / (2\pi f)^2 C$ Henry

9 What are the applications of wheat stone bridge and explain its limitations?

Ans:

Applications of Wheatstone bridge

1. The basic application of a Wheatstone bridge is measurement of resistance. It is used to measure medium resistance values.
2. It can also be used to measure inductance and capacitance values.
3. Various industrial applications involve measurement of physical quantities (such as temperature, pressure, displacement etc) in terms of electrical resistance. The various industrial applications in which a Wheatstone bridge is used are.
 - (i) Temperature measurement systems involving electrical resistance thermometers as temperature sensors.
 - (ii) Pressure measurement systems involving strain gauge as secondary transducer.
 - (iii) Measurement of static and dynamic strains.
 - (iv) It is used with explosive meter to measure the amount of combustible gases in a sample.
 - (v) Temperature measurement systems involving electrical resistance thermometers as temperature sensors.
 - (vi) Pressure measurement systems involving strain gauge as secondary transducer.
4. Measurement of static and dynamic strains.
5. It is used with explosive meter to measure the amount of combustible gases in a sample.

Limitations of Wheatstone bridge

1. Wheatstone bridge is not suitable for measuring low resistances because the resistance of leads and contacts of the bridge cause errors in the value measured by the Wheatstone bridge and thus affects the measurement of low resistances.
2. Wheatstone bridge cannot be used for measurement of high resistance also, because a galvanometer is not sensitive to the imbalance of the bridge caused by the high resistance of the bridge. This problem can be overcome by replacing the galvanometer with a Vacuum Type Volt Meter (VTVM) and by replacing the battery with a power supply.

3. A Wheatstone bridge cannot be used in high temperature or temperature-varying environment because the resistance of the arms of the bridge changes due to change in temperature.

4. The resistance of the bridge arms also changes due to heating effect of the current passing through the resistance. Flow of very large current through the resistors leads to a permanent change of resistance value .

10. Explain the FM recording method?

Ans:

FM Recording

In FM (Frequency Modulation) recording technique the principle for recording an input signal is as follows,

A high frequency carrier signal is frequency modulated by the input signal (i.e. the signal to be recorded) and then this frequency modulated carrier signal is recorded and reproduced by the basic magnetic recording procedure. The input signal is extracted from the reproduced modulated waveform by processing it through a demodulator and low pass filter. The frequency with which the carrier signal oscillates is known as centre frequency (f_c).

A frequency modulation recording system consists of a frequency modulator, frequency demodulator, a low pass filter and the basic magnetic recording circuit as shown in the figure (1) below.

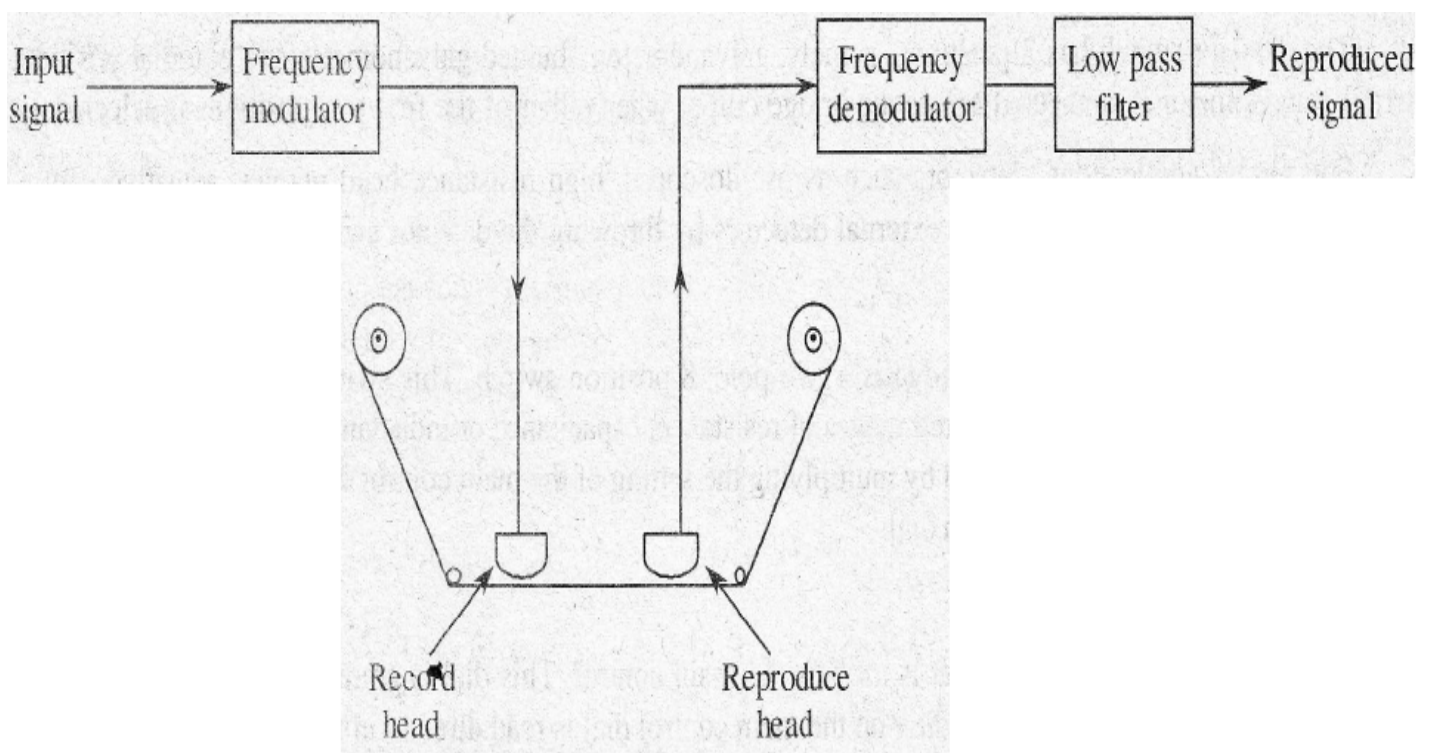

fig 10.1 Block Diagram of FM recorder

When the input signal (to be recorded) is applied to the frequency modulator, the frequency of the carrier signal gets modulated as per the frequency level of the input signal. When there is no input (i.e. input voltage = 0) the centre frequency of the carrier signal remains unchanged and hence the output of modulator oscillator at a frequency. When the input signal is applied and if the input voltage is positive, the carrier frequency gets deviated by certain percentage in one direction. If the input voltage is negative the carrier frequency gets deviated by certain percentage in the opposite direction. A positive voltage input signal increases the carrier frequency f_c , while a negative voltage input signal decreases the carrier frequency, as shown in the figure (2) below.

For A.C input signals, the output of the modulator will be a signal of varying frequency, and the variation in frequency is directly proportional to the amplitude (voltage) of the input signal.

The output of the frequency modulator is then fed to the recording head of the system. The recording head records this modulated signal on the magnetic tape. Later, when the tape is passed through the reproduce head, it produces a voltage which represents the same modulated waveform being recorded on the tape. The output of the reproduce head is then demodulated by passing it through a frequency demodulator. Hence, the output of the demodulator consists of carrier frequency and other unwanted frequencies along with frequency of input signal. In order to remove these unwanted frequencies the output of the demodulator is given to low pass filter, which allows the frequency components of only input signal to pass through it. Thus, in this way a signal is recorded and reproduced by *FM* recording technique.

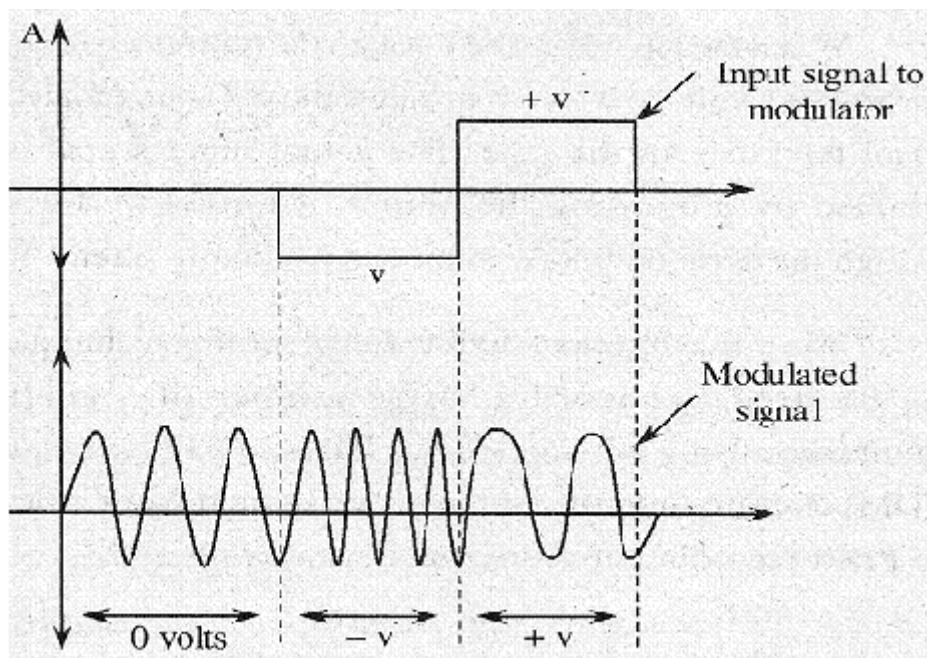

fig 10.2 Output of frequency modulator

Advantages of FM Recording

1. In FM recording technique, the D.C component of the signal being recorded is preserved.
2. In this recording technique, the recorded signal is accurately reproduced because this technique is independent of amplitude variations.
3. It is widely employed for recording the output voltages of transducers such as force, pressure or acceleration transducers.
4. It is also used in instrumentation systems for multiplexing purposes.
5. FM recorders can record a wide range of frequency signals i.e. D.C signals to several kHz signals.

Disadvantages of FM Recording

1. FM recording systems are more complex than direct recording systems because FM recorders utilize modulation and demodulation devices.
2. FM recording is very sensitive to fluctuations in speed of tape. The variations in tape speed leads to unnecessary modulation of the carrier signal.
3. For efficient recording, the FM recording technique requires the tape speed to be high and constant.
4. FM recorders are costlier than direct recording systems because they require a high quality of tape transport and speed control.
5. The frequency response of FM recorders is limited to 80 kHz.